

## FEATURES

- Programmable Output Voltage to 28V
- Guaranteed 0.5% Reference Voltage Tolerance
- Cathode Current Range (Continuous) 100 mA
- Temperature Compensated For Operation Over Full Rate Operating Temperature Range
- Low Output Noise Voltage
- Fast Turn-on Response
- Available in TO-92, SOT-89 and SOT-23 Packages

## APPLICATIONS

- Shunt Regulator
- Precision High-Current Series Regulator
- High-Current Shunt Regulator
- Crowbar Circuit
- PWM Converter With Reference
- Voltage Monitor
- Precision Current Limiter

## DESCRIPTION

The TJ431 is a three-terminal adjustable shunt regulator with specified thermal stability over applicable temperature  $V_{REF}$  (2.495V) and 28V with two external resistors. This device has a typical dynamic output impedance of  $0.25\Omega$ . Active output circuitry provides a very sharp turn-on characteristic, making this device excellent replacement for Zener diodes in many applications. The TJ431 is characterized for operation from  $-40^{\circ}\text{C}$  to  $+125^{\circ}\text{C}$ .

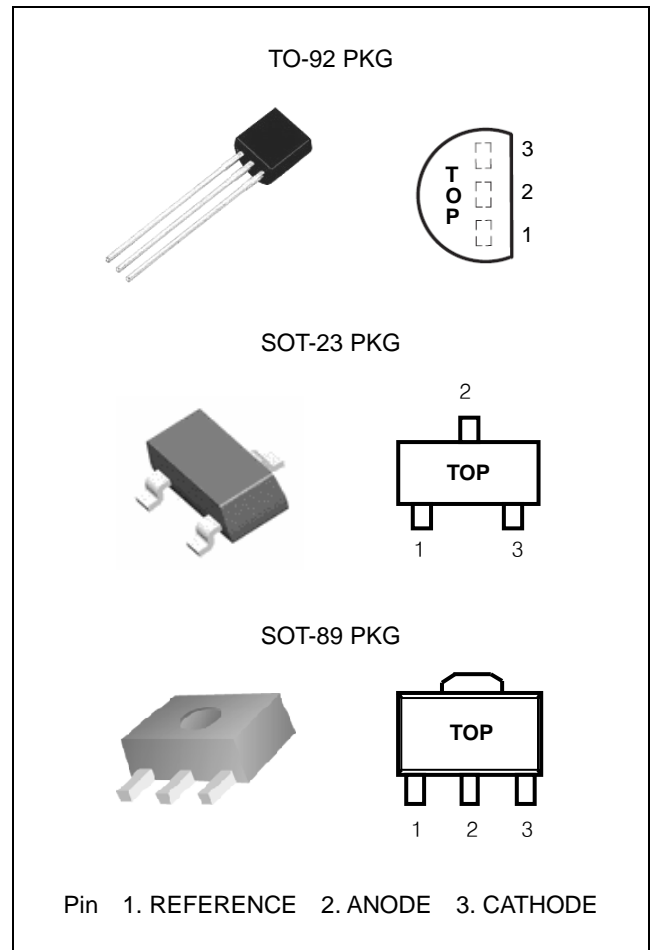

## ORDERING INFORMATION

Device	Package
TJ431x	TO-92 (Bulk)
TJ431xTA	TO-92 (Taping)
TJ431xSF	SOT-23-3L
TJ431xF	SOT-89-3L

\* Refer to the ordering information for the details.

## ABSOLUTE MAXIMUM RATINGS

(Full operating ambient temperature range applies unless otherwise noted.)

PARAMETER	SYMBOL	MIN.	MAX.	UNIT
Cathode Voltage	$V_{KA}$	-	37	V
Cathode Current Range	$I_{KA}$	-100	150	mA
Reference Input Current Range	$I_{REF}$	-0.05	10	mA
Junction Temperature Range	$T_J$	-40	150	$^{\circ}\text{C}$
Storage Temperature Range	$T_{STG}$	-65	150	$^{\circ}\text{C}$

# Programmable Precision Shunt Regulator

# TJ431

## RECOMMENDED OPERATING CONDITIONS

PARAMETER	SYMBOL	MIN.	MAX.	UNIT
Cathode Voltage	$V_{KA}$	$V_{REF}$	28	V
Cathode Current	$I_{KA}$	1.0	100	mA
Operating Temperature Range	$T_{OPR}$	-40	125	°C

## ORDERING INFORMATION

VREF	Package	Tolerance	Order No.	Package Marking	Supplied As
2.495V	TO-92	0.5%	TJ431C	-	Bulk
			TJ431GC	-	
			TJ431CTA	-	Tape
			TJ431GCTA	-	
		1%	TJ431A	-	Bulk
			TJ431GA	-	
			TJ431ATA	-	Tape
			TJ431GATA	-	
		2%	TJ431	-	Bulk
			TJ431G	-	
			TJ431TA	-	Tape
			TJ431GTA	-	
	SOT-23	0.5%	TJ431CSF	-	Reel
			TJ431GCSF	-	
		1%	TJ431ASF	-	Reel
			TJ431GASF	-	
		2%	TJ431SF	-	Reel
			TJ431GSF	-	
	SOT-89	0.5%	TJ431CF	-	Reel
		1%	TJ431AF	-	Reel
		2%	TJ431F	-	Reel

## ORDERING INFORMATION (continued)

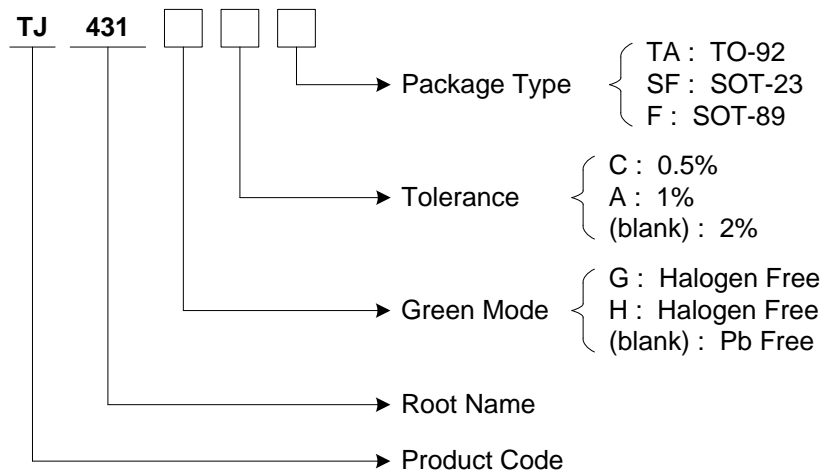

## PIN CONFIGURATION

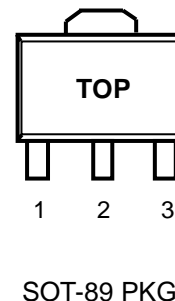
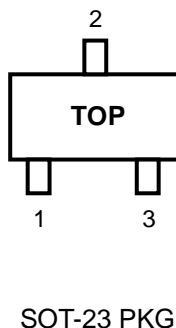
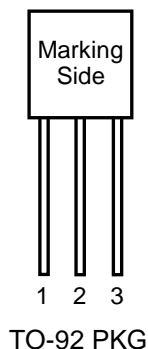

## PIN DESCRIPTION

Pin No.	TO-92 / SOT-23 / SOT-89	
	Pin Name	Pin Description
1	REFERENCE	Reference Voltage
2	ANODE	Ground
3	CATHODE	Input Supply Voltage

## BLOCK DIAGRAM

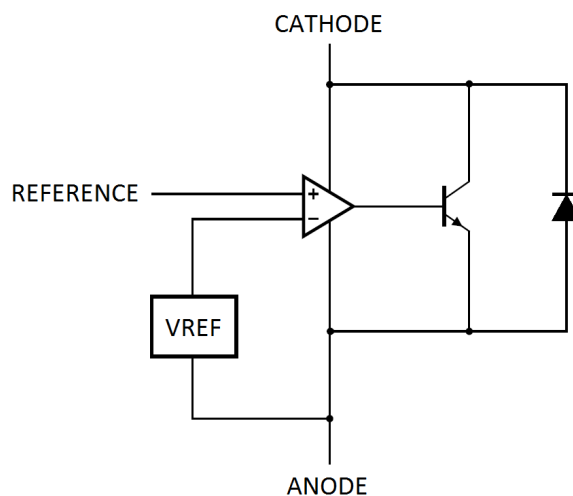

## ELECTRICAL CHARACTERISTICS

(T<sub>A</sub>=25°C, unless otherwise specified)

PARAMETER	SYMBOL	TEST CONDITIONS	MIN.	TYP.	MAX.	UNIT	
Reference Input Voltage	V <sub>REF</sub>	V <sub>KA</sub> =V <sub>REF</sub> , I <sub>K</sub> =10mA	TJ431C	2.483	2.495	2.507	V
			TJ431A	2.470	2.495	2.520	
			TJ431	2.440	2.495	2.550	
Deviation of Reference Input Voltage (Note 1)	ΔV <sub>REF</sub> /ΔT	V <sub>KA</sub> = V <sub>REF</sub> , I <sub>K</sub> = 10mA T <sub>A</sub> = Full Range		35	50	mV	
Ratio of Change in Reference Input Voltage to the Change in Cathode Voltage	ΔV <sub>REF</sub> /ΔV <sub>KA</sub>	I <sub>K</sub> = 10mA	ΔV <sub>KA</sub> = 10V to V <sub>REF</sub>	-1.0	-2.7	mV/V	
			ΔV <sub>KA</sub> = 28V to 10V	-0.4	-2.0		
Reference Input Current	I <sub>REF</sub>	I <sub>KA</sub> = 10mA, R <sub>1</sub> = 10kΩ, R <sub>2</sub> = ∞		0.5	1.2	μA	
Deviation of Reference Input Current (Note 1)	ΔI <sub>REF</sub> /ΔT	I <sub>K</sub> = 10mA, R <sub>1</sub> = 10kΩ, R <sub>2</sub> = ∞ T <sub>A</sub> = Full Range		0.4	1.2	μA	
Minimum Cathode Current for Regulation	I <sub>K(MIN)</sub>	V <sub>KA</sub> = V <sub>REF</sub>		0.4	1.0	mA	
Off-State Cathode Current	I <sub>K(OFF)</sub>	V <sub>KA</sub> = 28V, V <sub>REF</sub> = 0		0.1	1.0	μA	
Dynamic Impedance (Note 2)	Z <sub>KA</sub>	V <sub>KA</sub> = V <sub>REF</sub> , I <sub>K</sub> = 1mA~100mA f ≤ 1kHz		0.25	0.50	Ω	

(Note 1) The deviation parameters ΔV<sub>REF</sub>/ΔT<sub>A</sub> and ΔI<sub>REF</sub>/ΔT<sub>A</sub> are defined as the differences between the maximum and minimum values obtained over the recommended temperature range. The average full-range temperature coefficient of the reference voltage, αV<sub>REF</sub>, is defined as:

$$|\alpha V_{REF}| \text{ (ppm/°C)} = \frac{\left( \frac{V_{I(dev)}}{V_{REF \text{ at } 25^\circ\text{C}}} \right) \times 10^6}{\Delta T_A}$$

Where:

ΔT<sub>A</sub> is the recommended operating free-air temperature range of the device.

αV<sub>REF</sub> can be positive or negative, depending on whether minimum V<sub>REF</sub> or maximum V<sub>REF</sub>, respectively, occurs at the lower temperature.

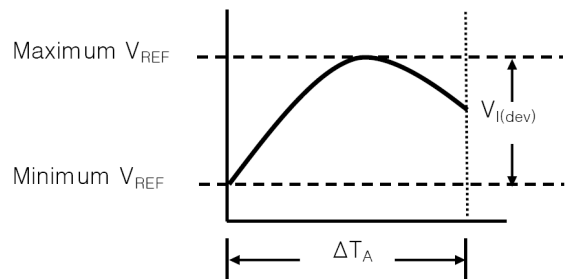

Example : Maximum V<sub>REF</sub>=2496mV at 30°C, minimum V<sub>REF</sub>=2492mV at 0°C, V<sub>REF</sub>=2495mV at 25°C, ΔT<sub>A</sub>=70°C for TJ431C.

$$|\alpha V_{REF}| = \frac{\left( \frac{4\text{mV}}{2495\text{mV}} \right) \times 10^6}{70^\circ\text{C}} \approx 23\text{ppm/°C}$$

Because minimum V<sub>REF</sub> occurs at the lower temperature, the coefficient is positive.

(Note 2) The dynamic impedance is defined as:  $|Z_{KA}| = \frac{\Delta V_{KA}}{\Delta I_{KA}}$

When the device is operating with two external resistors, the total dynamic impedance of the circuit is given by:

$$|Z| = \frac{\Delta V}{\Delta I} \approx |Z_{KA}|(1 + R1/R2)$$

## TEST CIRCUITS

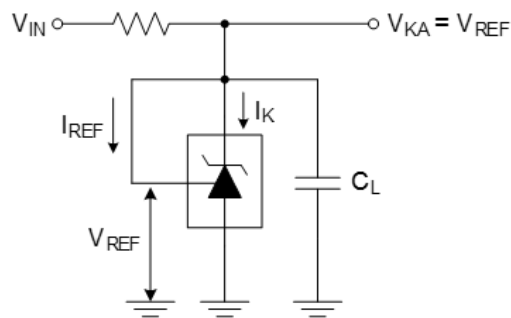

< Fig 1. Test circuit for  $V_{KA} = V_{REF}$  >

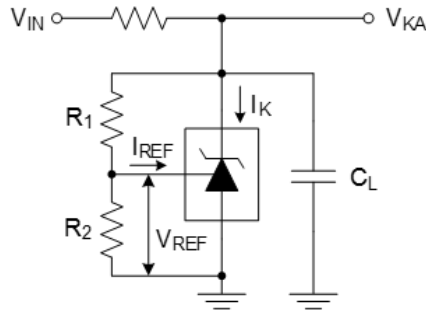
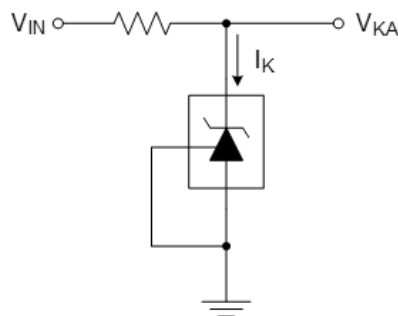

Fig 2. Test circuit for  $V_{KA} \geq V_{REF}$  >



< Fig 3. Test circuit for  $I_{KA(OFF)}$  >

## REVISION NOTICE

The description in this datasheet is subject to change without any notice to describe its electrical characteristics properly.