



TL2494

Preliminary

CMOS IC

CC CONTROL FOR CAR BALLAST

DESCRIPTION

UTC **TL2494** is a constant current chip, used car ballast, through peripheral resistance can output constant current value. It is also built-in UVLO, Open circuit protect, Over current protect, overload protect, etc.

FEATURES

- * 6 ~ 40V input
- * UVLO
- * Open circuit protect
- * Overload protect

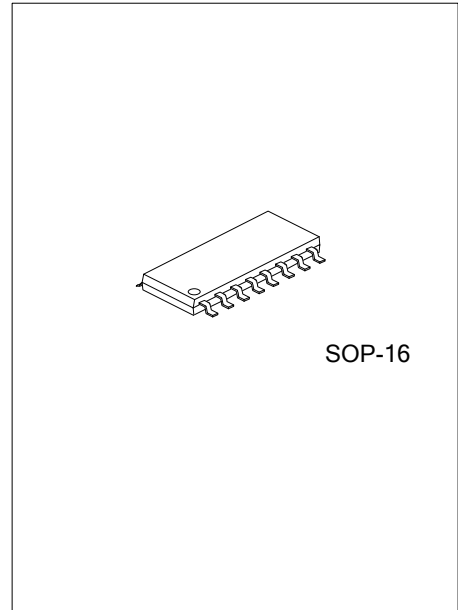

ORDERING INFORMATION

Ordering Number		Package	Packing
Lead Free	Halogen Free		
TL2494L-S16-R	TL2494G-S16-R	SOP-16	Tape Reel

<p>TL2494G-S16-R</p> <ul style="list-style-type: none"> (1) Packing Type (2) Package Type (3) Green Package 	<ul style="list-style-type: none"> (1) R: Tape Reel (2) S16: SOP-16 (3) G: Halogen Free and Lead Free, L: Lead Free
--	--

MARKING

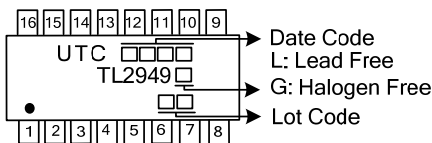

■ PIN CONFIGURATION

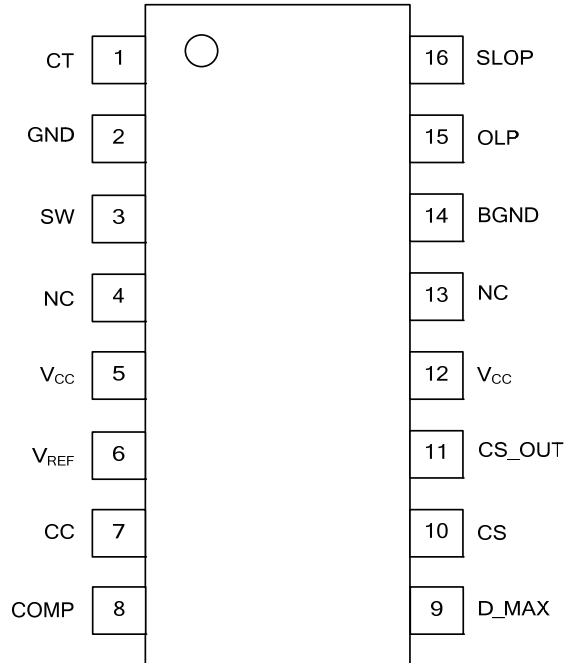

■ PIN DESCRIPTION

PIN NO.	PIN NAME	DESCRIPTION
1	CT	OSC
2	GND	Ground
3	SW	Switch PIN, control power MOS gate
4, 13	NC	No bonding
5, 12	V _{CC}	Supply Voltage
6	V _{REF}	Band gap reference
7	CC	Constant current control
8	COMP	Compensation
9	D_MAX	MAX. duty ratio
10	CS	Current detection
11	CS_OUT	Current detection out
14	BGND	No bonding
15	OLP	Overload protect
16	SLOP	Slop Compensation

■ BLOCK DIAGRAM

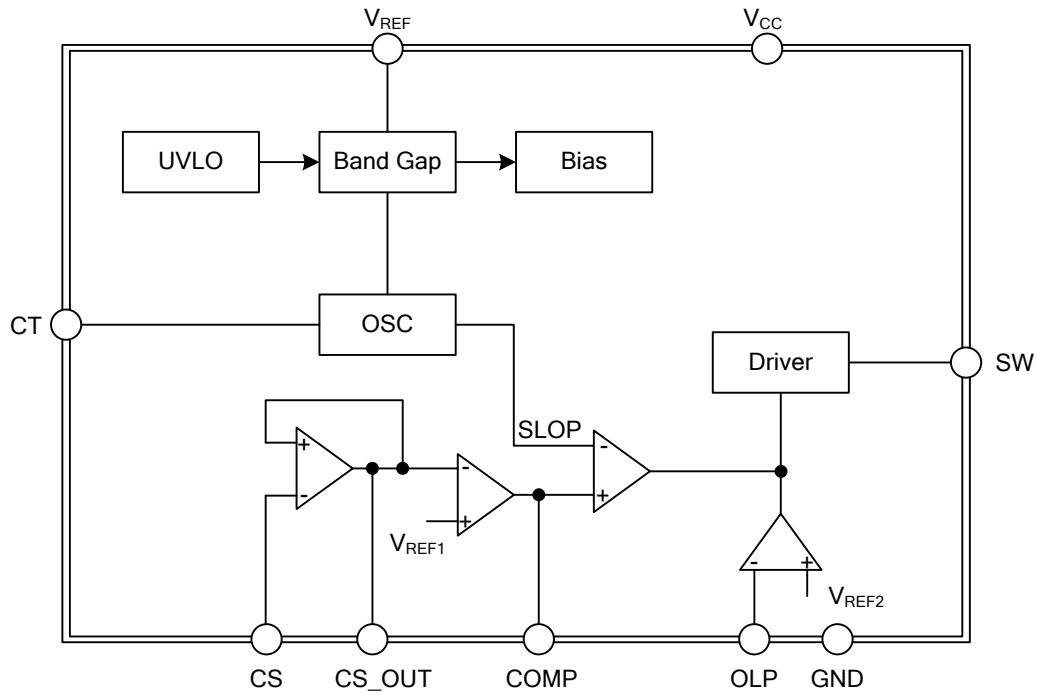

■ ABSOLUTE MAXIMUM RATING

PARAMETER	SYMBOL	RATINGS	UNIT
Supply Voltage	V_{CC}	40	V
Power Dissipation ($T_A=25^\circ\text{C}$)	P_D	1000	mW
Junction Temperature	T_J	125	$^\circ\text{C}$
Operating Temperature	T_{OPR}	-25 ~ +85	$^\circ\text{C}$
Storage Temperature	T_{STG}	-40 ~ +150	$^\circ\text{C}$

Note: Absolute maximum ratings are those values beyond which the device could be permanently damaged. Absolute maximum ratings are stress ratings only and functional device operation is not implied.

■ RECOMMENDED OPERATING CONDITIONS

PARAMETER	SYMBOL	RATINGS	UNIT
Supply Voltage	V_{CC}	6 ~ 40	V
Timing Capacitor	C_T	3.3	nF
Timing Resistor	R_T	7.5	K Ω

■ ELECTRICAL CHARACTERISTICS ($T_A=25^\circ\text{C}$, unless otherwise specified)

PARAMETER	SYMBOL	TEST CONDITIONS	MIN	TYP	MAX	UNIT
Supply Current	I_Q	$V_{CC}=12\text{V}$		14	18	mA
UVLO	V_{RISE}	RISE		6.5		V
	V_{FALL}	FALL		6.5		V
Band Gap Voltage	V_{REF}	$V_{CC}=12\text{V}$	4.95	5	5.05	V
OSC Frequency	F_{OSC}	$C_T=3.3\text{nF}$, $R_T=7.5\text{k}$	60	65	70	KHZ
Triangle Wave of Upper	$V_{FOSC\ MAX}$			2.7		V
Triangle Wave of Lower	$V_{FOSC\ MIN}$			0.8		V
Sampling Current Magnification	I_{AMP}			20		

■ TYPICAL APPLICATION CIRCUIT

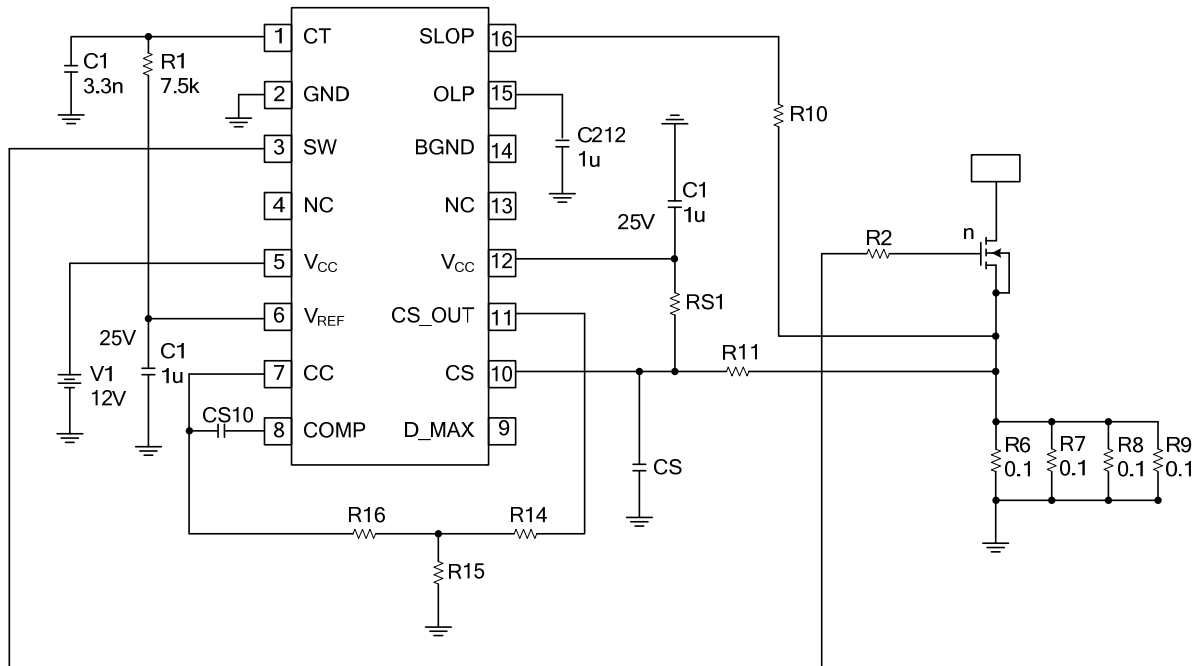

UTC assumes no responsibility for equipment failures that result from using products at values that exceed, even momentarily, rated values (such as maximum ratings, operating condition ranges, or other parameters) listed in products specifications of any and all UTC products described or contained herein. UTC products are not designed for use in life support appliances, devices or systems where malfunction of these products can be reasonably expected to result in personal injury. Reproduction in whole or in part is prohibited without the prior written consent of the copyright owner. The information presented in this document does not form part of any quotation or contract, is believed to be accurate and reliable and may be changed without notice.